

ISO
9001:2008
REGISTERED



SGS



BUREAU
VERITAS



www.synmec.com

SYNMEC

5XZF-7.5F Seed Cleaner & Grader

Primary cleaner with double air cleaning system and stone removing function.
It also can remove dust, light impurity, small impurity and big impurity.



SYNMEC

The world top Manufacturer for Grain Cleaning Solutions
Adviser for Seed Processing

INTRODUCTION

Seed cleaner & grader is used for cleaning and grading seeds, grains, cereals, and other granule products. It can be equipped to suit a variety of special jobs and purposes.

Dust and light impurity are removed by aspirator fan. Material falls on sieve layers and was separated by sieves according to width and thickness difference. All the oversize and undersize impurities were discharged from different outlets.

FEATURES

Seed cleaner & grader becomes basic and most favourite cleaning machine in seed and grain industry of global market, with high efficiency, excellent performance, wide application.

It's suitable for processing all kind of seeds, cereals, grains species and crops, such as wheat, paddy, rice, barely, maize, millet, cumin, sunflower seed, soybean, coffee bean, cocoa bean, oil seeds, etc.

Customized sieve layer amount and various machine combinations allow the seed cleaner & grader to be used for a wide range of applications and increase grading efficiency.



Working principle sketch

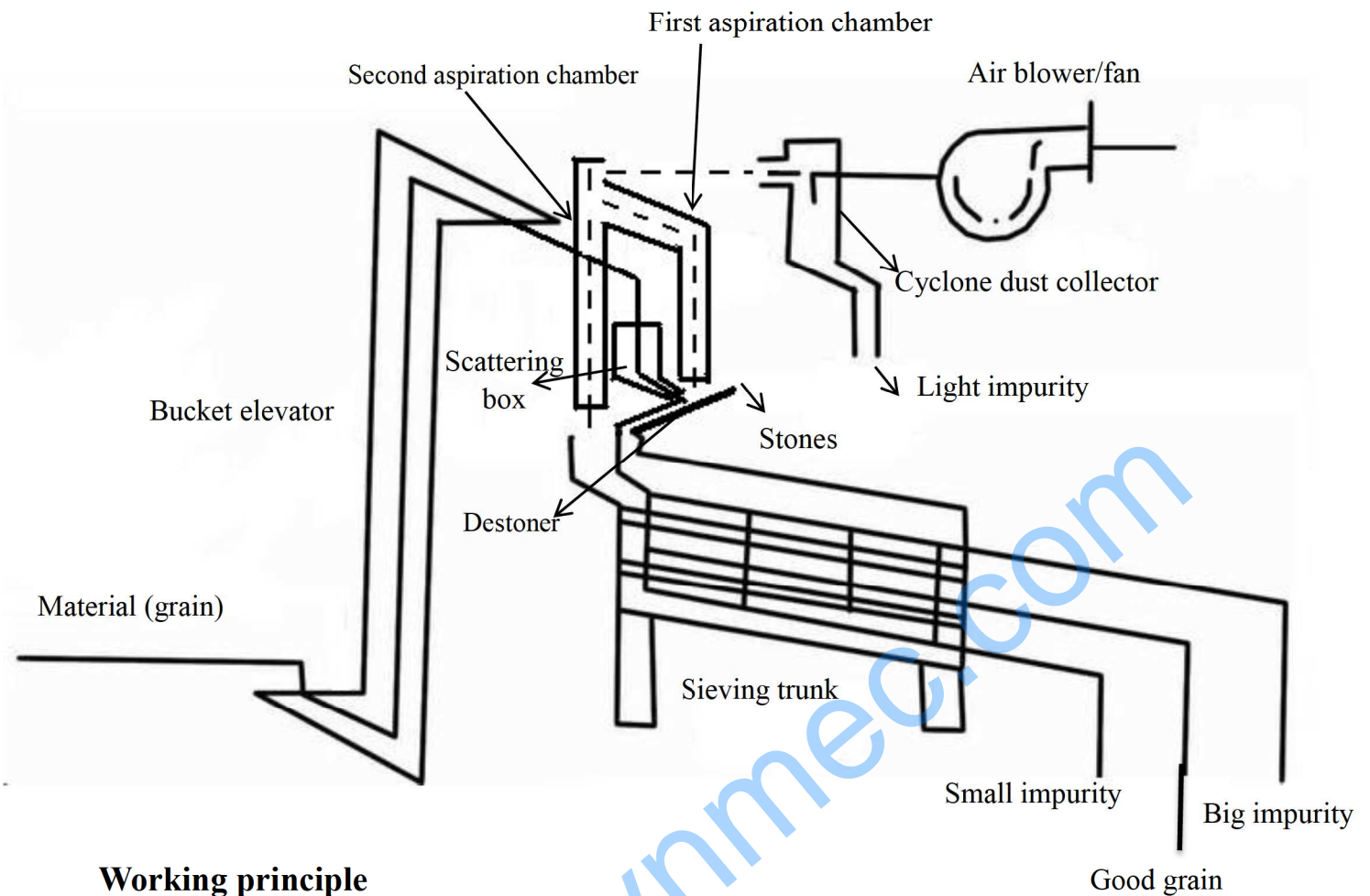

Working principle

Feeding the grain into inlet hopper then lifting up by bucket elevator, following flow to the scattering box, then enter to first air chamber for first time air cleaning, following drop to stone removing deck which equipped louver sieve for quick remove some big stones, that is under the first air chamber, then flow to front air chamber for second time air cleaning, and then under the vibration the grain jumping and flow to the four layers sieving trunk, following the grains well-proportioned enter to the upper layer sieve via the rubber curtain. Selected grains will fall into the next lower sieving panel after sieving, chaff and debris blocked by sieves and transfer to the outlet of large impurity. The selected grains will fall into the lower layers sieving panels, and will be graded into different levels of the different grain sizes by sieving in different sieving layers, that caused by the layers sieving panels have different mesh size. Selected grains flow to the outlets of good grain, fill into bag hung on the bag holder. Cap of outlets can be used when shift bagging that means the cap can be close when you change the bag. It is the whole work flow for the separator.

Use different sieve to different process of different type of grains. The observing windows on the sieving trunk are for checking operation.

Multi-angle display



Aspiration Chambers (Wind Sieve)

Removing dust, straws, hay, husk and other light weight impurity out of the grain.

Handles and *knobs* adjusting the gap of channel (wide at top and narrow at bottom) to obtain optimum aspiration separating result. Removal of all the light weight impurity while fine seed falling down. Double aspiration chamber, better for removing light impurity



Observation window

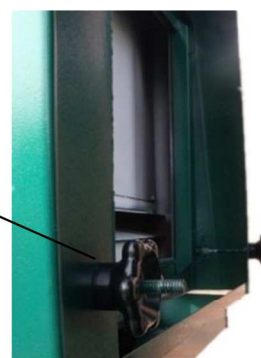

Dust removing system

Dust cyclone separator is a professional method of removing particulates from an air, gas or liquid stream, without the use of filters. Rotational effects and gravity are used to separate mixtures of solids and fluids.

Air flow adjusting handle

Optional Gear motor

(not standard equipped)

Air lock discharge the impurity from dust cyclone

separator and keep air pressure of aspiration system

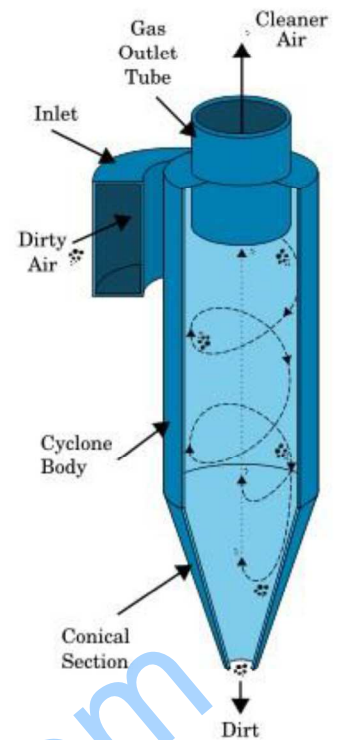
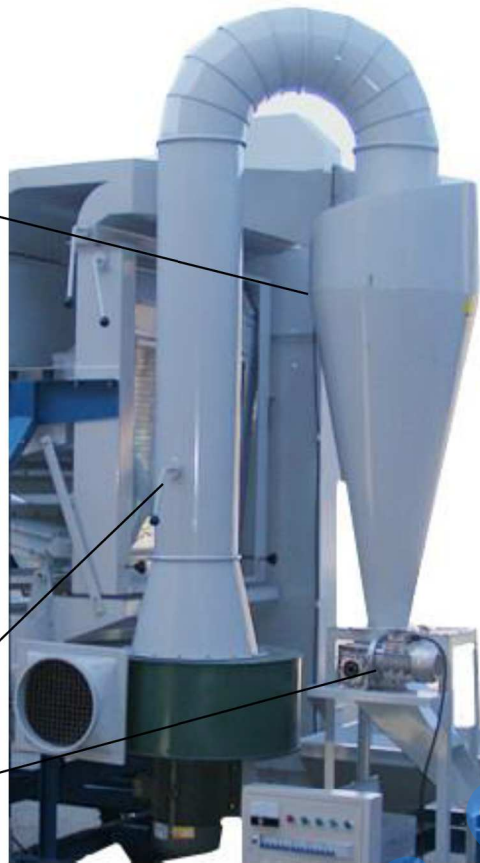

Seed separating flow



Optional Gear motor

(not standard equipped)



Handle for adjusting grain flow scattering evenly

Grain lifted up by bucket elevator and fall into grain scattering box, where grain flow scatter evenly, in case of the grain gather at one side. Then grain drop on the stone removing deck for stone removal and first aspiration.

On the stone removing deck, stone climb up and discharge from top end. Grain flow to second aspiration and fall into sieving trunk and light impurity was removed by aspiration simultaneously.



Grain flow

Grain scattering box spread grain evenly for better aspiration effect and selecting

Handles for adjusting aspiration chamber gap

Destoner device is feature of 5XZF-7.5F model, which is design for removing stone and rock, suitable for grains with some stones.

Stone is collected at top end outlet.

In this part, grain / seed was graded by galvanize sheet with different holes in each layer. Big size and small size impurity discarded in different outlets respectively. Final cleaned seed come out from main outlet.

Sack frame Outlets



Star shape Handle
Fixed the sieves, the sieves can be easily changed.

Stone removing deck which equipped louver sieve



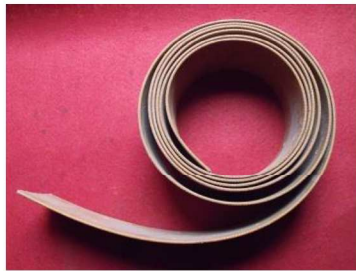

Bucket elevator

Used to transfer materials (grains). Available in both fixed and movable version to adapt different working environment.

Feature

It has compact structure, user friendly interface, easy to maintain, energy saving, easy to clean, efficiently avoid mixture.

Power control cabinet

It has the feature of easily operating, only need to connect the power. The wire is 100% copper, which lead to long using life.

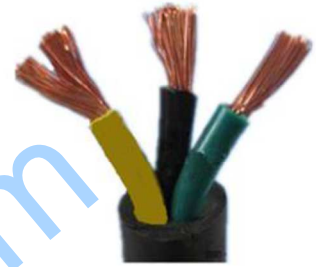

It's very convenient to pull the sieves out. Client can change the sieve easily when cleaning other grain or seed.



The sieves inside are made of durable galvanized steel sheet. We will equip suitable sieves hole according to client's raw material.

In order to choose perfect sieves, the seed sample (raw material contains impurities) or seed measuring photo are needed after clients placed order. Note that one set sieves are equipped as standard supply, only used for one species seed.

Knobs and plates press the sieves firmly



Rubber ball
for sieve clog
cleaning



Note: Stainless steel sieve is available.

Hebei motor, is a famous brand which certified by the nation. It has win an excellent reputation for both its high quality and favorable price.



Two fan shaped metals in two ends of vibration motor set the vibration amplitude.

Engineer will set it before delivery. Not recommend setting by users.

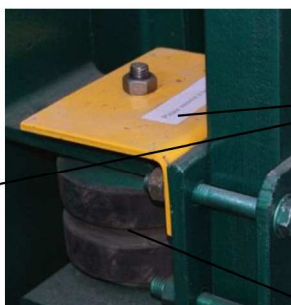

Fixing plates protect the rubber springs in transportation.

Please remove them before start the machine.

Rubber spring support sieving trunk

Dimension (L×W×H)	5600×2000×3200 mm
Dimension of each sieve layer	2400×1250 mm
Capacity (count by wheat)	7500 kg/h
Weight	1800 kg
Motor Power	
Air Blower	7.5 kw
Vibration Motors	0.55 kw*2
Elevator Motor	0.75 kw
Air Lock	0.75 kw
Total Power	10.1 kw



We have installed the tractive load frame and wheel, so you can easy take it to the field.

Model Directory for Seed (Grain) Cleaner & Grader

No.	Model	Capacity (counted by wheat)	Available Sieve Layers (by Customer require)	Wheat Huller	Maize Thresher	Rice deawner	Dust Reducer	Cyclone Dust Separator	Double Air Cleaning Systems	Destoning function
1	5XZC-3A	3 T/H	2-3		✓		✓			
2	5XZC-3B	3 T/H	2-3				✓			
3	5XZC-3C	3 T/H	2-3	✓			✓			
4	5XZC-3DH	3 T/H	2-3					✓		
5	5XZC-3DS	3 T/H	2-3					✓	✓	
6	5XZC-3P	3 T/H	2-3			✓		✓		
7	5XZC-5A	5 T/H	2-4		✓		✓			
8	5XZC-5B	5 T/H	2-4				✓			
9	5XZC-5C	5 T/H	2-4	✓			✓			
10	5XZC-5CDH	5 T/H	2-4	✓				✓		
11	5XZC-5DH	5 T/H	2-4					✓		
12	5XZC-5DS	5 T/H	2-4					✓	✓	
13	5XZC-5DSH	5 T/H	2-4				✓	✓		
14	5XZC-5P	5 T/H	2-4			✓		✓		
15	5XZC-7.5D	7.5 T/H	3-5					✓		
16	5XZC-15	10 T/H	3-6					✓		
17	5XZC-15A	10 T/H	3-6		✓		✓			
18	5XZC-25	20 T/H	4					✓	✓	
19	5XZD-15AC	20 T/H	Double 3					✓		
20	5XZF-5F	5 T/H	2-4					✓	✓	✓
21	5XZF-7.5F	7.5 T/H	3-5					✓	✓	✓

- Note:
- About sieve layer: two sieve layers is basic, normally top layer remove large impurity and bottom layer remove small impurity, add more sieve layer that can grade your seed/grain to different levels by size, such as add one more layer that can grade your seed/grain to two levels (big and small).
 - For 5XZD-15AC has double three sieve layers, which has two isolated sieving trunks installed in one machine, lead to double capacity
 - Dust reducer and cyclone dust separator are all used for collect the light impurity and dust which sucked by air blower, the cyclone dust separator is high technical one which can collect over 98% dust and light impurity, so very low dust release from the outlet of air blower. But the dust reducer only can collect most light impurity and few dust, so there are many dust release from the outlet of air blower.
 - 5XZC-5DSH has dust reducer and cyclone dust separator together, which used to separate the light impurity and dust when the light impurity is valuable, also provide better dust collection at the same time. Most light impurity will be collected by the dust reducer.
 - 5XZC-3DS and 5XZC-5DS has double air cleaning systems which placed at the front and back of the sieving trunk. Double air cleaning systems of 5XZC-25, 5XZF-5F and 5XZF-7.5F are all placed the front of sieving trunk.
 - Double air cleaning systems will lead to better air cleaning result.

We are the best choice for you!

Factory view



We have professional manufacturing equipment!

Drilling and milling machine	CNC lathe	Laser cutting machine
		
Plasma cutting machine	Bending machine	Shearing machine
		

We can provide over sea machine assembly and staff training services!



We have strong production capacity!



One time produce 6 sets 5XZD-15AC



One time produce 33 sets QSX-85 Destoner



One time produce 40 sets 5XZ-6 Gravity Separator



One time produce 30 sets 5BY-5B Seed Coating Machine

We have customers all over the world!



Healthy Grain, Pretty Beans, Strong Seed. SYNMEC

We serve for



Shijiazhuang SYNMEC International Trading LTD. and Hebei RUIXUE Grain Selecting Machinery Limited have all the copyright of the information and pictures provided in this leaflet. We have all the rights to do necessary adjustments on the product, and these changes may not reflect on the leaflet at the moment of production.

Address:
Head office: 15th Guangan Street,
Shijiazhuang City, Hebei Province,
China 050011
Manufactory: Huaihe Industry Park,
Hongqida Street, Shijiazhuang City,
Hebei Province, China 050000

Tel: +86 311 676663887
+86 311 89901997
Fax: +86 311 67663887
Mobile: +86 13273161281 (Tony)
Whatsapp: +86 13803340060
Imo: +86 13803340060
Wechat: 13803340060
Email: tony@synmec.com